

#### FEATURES

- Eight Quad Isolated Bi-Directional Channels
- Direct Readback of Output Channel Status
- VAC Range 90 - 240 Vrms
- Output Channels set to user defined state if communications failure occurs
- 3000 Vrms Isolation Input, Power and Network
- 2000 Vrms Channel-to-Channel Isolation
- 250Vrms Signal Overrange Protection
- Wide Range 9-36 VDC or 7-28 VAC Supply
- -40 to 85 °C Operating Temperature Range
- Complies with the requirements of IEC61000-6-5 and IEC61326-1

#### PRODUCT OVERVIEW

This Modbus RTU version 240VAC Bi-Directional Digital Module features 8 Isolated independent Bi-Directional channels and an isolated RS-485 interface.

An Input on the same channel can serve for direct readback of Output status.

The channels are fully isolated with 3000 Vrms between Input, Power, RS-485 link and 2000Vrms Channel-to-Channel. All channels feature 250Vrms Overrange Protection.

Eight Green and 8 Red LEDs provide IN-OUT Status Indication.

Communications Watchdog Timer will set Output channels to user defined State if communications failure occurs.

Plug-in Terminal blocks with Ejection lever enable easy installation and replacement.



## SPECIFICATIONS

#### Maximum Ratings

Power Supply Voltage	39 VDC or 29 VAC
VAC In-Out Overload	250 Vrms continuous
Storage Temperature	-55 to 125 Deg C
Channel Common Mode	3 KVrms (1 min)
Channel to Channel Voltage	2 KVrms (1 min)
RS-485 Common Mode	2.5 KVrms (1 min)

#### Emissions & Immunity

Complies with the requirements of IEC61000-6-5 and IEC61326-1	
In particular :	
IEC61000-3-2	Class B emissions
IEC61000-4-2	8 KV electrostatic discharge
IEC61000-4-4	4 KV burst, 5/50 ns, 5 Khz
IEC61000-4-5	4 KV surge 1.2/50 us, line to ground, 2 KV line to line
IEC61000-4-6	Conducted RF

#### VAC In-Out

Voltage Range	90 - 240 Vrms
Input Threshold	75 V
Input Resistance	100 Kohm in series with 75V Zener
Output Load Current	500mA rms / Channel

#### Common Mode

Leakage Current	4 µA rms at 1000 Vrms and 50/60 Hz, per channel
Capacitance	8 pF max per channel

#### Power Requirements

Supply Voltage	9 to 36 VDC or 7 to 28 VAC
Max Power	1.4 W, Non Polarized

#### RS-485 Interface

Protocol	Modbus RTU
Baud Rate	2400 to 921.6K standard baud rates, default = 19200
Duplex	Half duplex
Parity	None
Data bits	8
Stop bits	2
Response Delay	0 to 6553.5 msec in 0.1 msec increments
Module Address	1 to 247
Max nodes	1 to 31 without repeater
Max distance	4000 ft, 1230 meters (varies with baud rate)

#### Environmental & Mechanical

Operating Temperature	-40 to 85 °C
Relative Humidity	< 95 % Non Condensing
Overall Dimensions	113.6 x 117.2 x 22.5 (mm ), 4.47 x 4.62 x 0.89 ( in )
Enclosure material	PA 66 GF 30
PC Board material	FR4
Protection Class	IP20
Conductor Size	AWG26 min, AWG14 max

## Functional Block Diagram

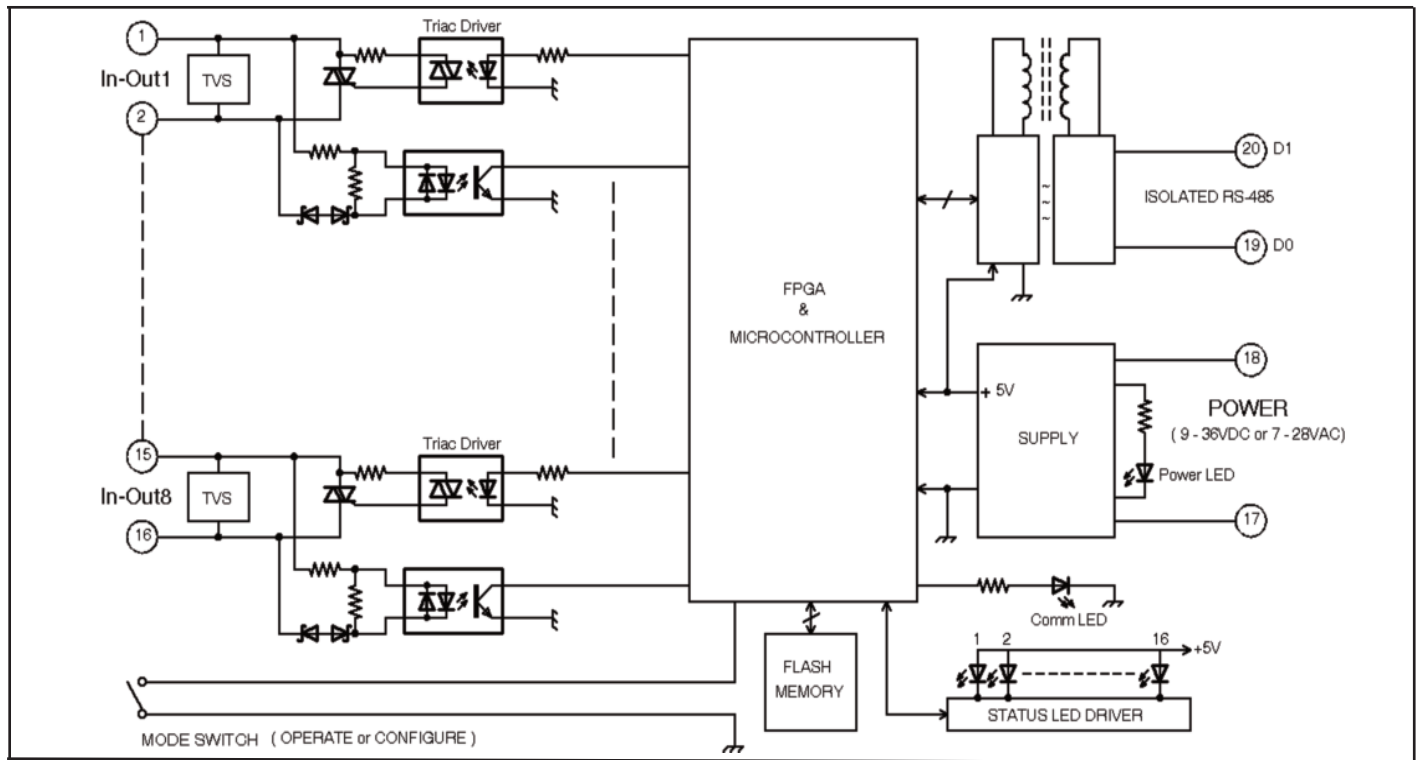

## OPERATION

The Functional Block Diagram shows how the external VAC Inputs and Outputs are connected to the eight identical isolated processing channels. Each channel has a Transient Voltage Suppressor Network across the I/O terminals, followed by an AC type optocoupler in parallel with a zero crossing TRIAC. The channel input resistance is 100 Kohm in series with a 75V Zener.

External power at the POWER terminals is indicated by the "Power" LED. The "Comm" LED turns ON when the module is transmitting. A Green Status LED for each channel is ON when the Input voltage is applied. A Red Status LED for each channel is ON when the Output is energized. **When the output is Energized (ON) and is driving a load, the associated readback value will be OFF and vice-versa.**

An isolated RS-485 interface drives the network cable. A watchdog timer will restart the module if any unusual event disrupts normal operation.

## INSTALLATION

### Enclosure

All ISODIN modules offer IP20 level protection to withstand typical industrial environments. The thermoplastic package is non-flammable per UL94 V-0 with high impact resistance.

They feature surge protection on each input and have low radiated emissions and high immunity tolerance.

### Mounting

This module must be mounted vertically on a 35mm "T" type DIN rail as per EN50022.

Module attachment is done by locating the top groove of the adapter over the upper lip of the rail then pushing the unit downwards until it snaps into place.

Removal is accomplished by inserting a screwdriver into the groove of the bottom side latch and using it as a lever to open the latch until the module disconnects from the rail.

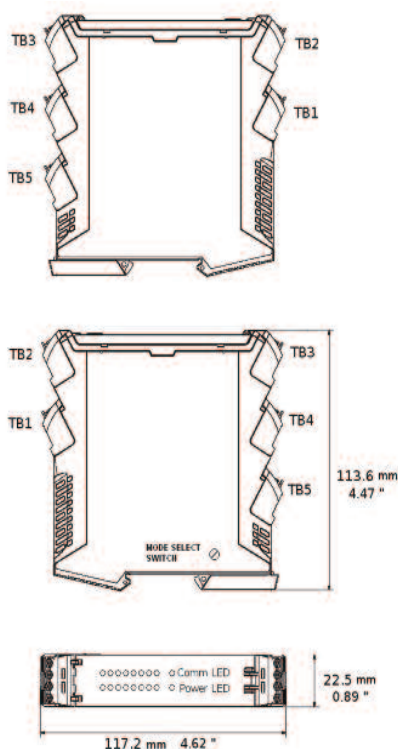

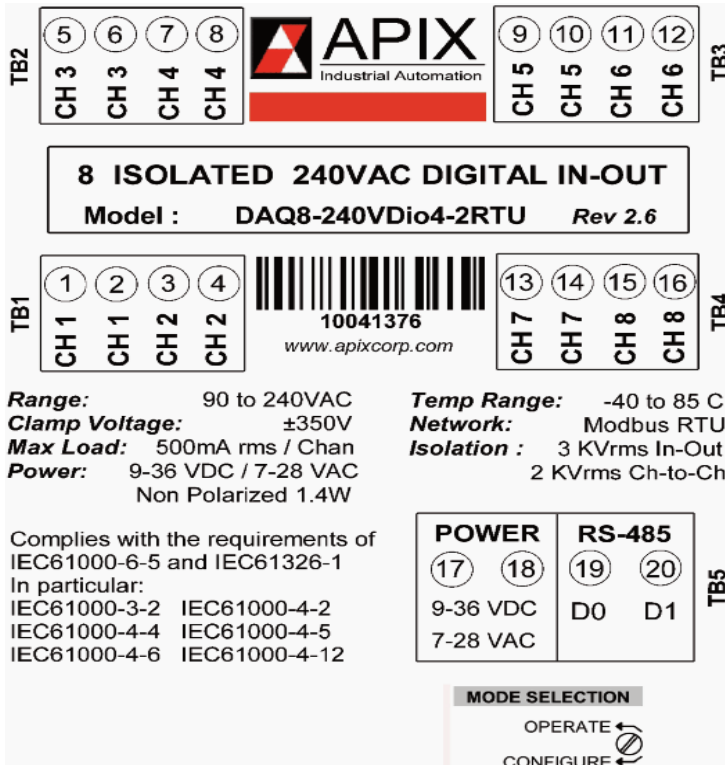

## CONNECTIONS

There are 5 plug-in terminal blocks, TB1—TB4 for Signal wiring and one 4 pin terminal, TB5 for power and RS-485 connections. These terminal blocks are clearly indicated on the module side label. TB1-TB5 have a convenient lever mechanism for easy ejection.

All terminals will accept from AWG26 up to AWD14 wire and are rated 10A/400V at ambient temperature and II/2 pollution severity.

The power input is Non-Polarized from 9 to 36VDC or 7 to 28VAC and connects to the POWER terminals. A Green LED, labeled “Power” on the front panel is fed directly by the power input.

A twisted pair cable should be used for the RS-485 signal and daisy chained from module to module, without branching. Terminals labeled D0 and D1, as per the Modbus specification, carry the differential half duplex RS-485 signal. A cable shield is not normally required but if available should be connected to chassis (DIN rail) ground. Since this RS-485 link is isolated, there is no current flow along the shield drain wire.

RS-485 line polarization is required for proper operation of this module. This is usually provided by the Modbus Master node via pullup and pulldown resistors. The Master node should also provide a 120 or 150 ohm line termination resistor across the D0 & D1 pins. If the cable is very long and reflections are a problem, then a second termination resistor, at the far end of the cable, may be required.

## CONFIGURATION

An external MODE Rotary Switch must be set to the “CONFIGURE” position (fully clockwise) in order to permit changes to all internal parameters. The procedure is as follows:

- 1) Power must be OFF
- 2) Turn MODE switch fully clockwise
- 3) Power ON
- 4) Change any parameters as necessary
- 5) Power OFF
- 6) Turn MODE switch fully counterclockwise (OPERATE position, default)
- 7) Power ON to operate normally

NOTE that the MODE switch state will be recognized only when power is applied.

In the CONFIGURE position, default communication parameters are set as follows:

Module address = 1  
Baud rate = 19200  
Sample rate = 1000

All user accessible parameters are stored in Flash memory and can be read and written to as "Holding Registers", via the Modbus RTU protocol ( function codes 3 and 6 ), in the following locations:

Register Address	Name	Value Range
0	Module ID	13 ( DAQ8-240VDin4-2RTU )
1	Module Address	1 to 247
2	Sample Rate	50 to 1000 HZ ( Default = 1000 )
3	Baud Rate	24 to 9216 (Actual rate divided by 100)
4	Parity	0=none
5	Response Delay	0 to 65535 ( equals 0 to 6553.5 msec ) ( Default = 0 )
6	Reserved	
7	Communications Watchdog Timeout	-1=Disable (default), 100 to 32767 = 0.1 to 327.67 Sec
8	Ch1 Output State	0=OFF 1=ON 2=No change of state
9	Ch2	" " "
10	Ch3	" " "
11	Ch4	" " "
12	Ch5	" " "
13	Ch6	" " "
14	Ch7	" " "
15	Ch8	" " "

Due to the nature of Flash memory, it can be read very quickly but when writing to a single location it actually writes a complete block of 65536 locations. This can take several seconds to complete.

The communications watchdog timer will time out if no message has been transmitted from the Modbus Master to any network node after a time period greater than the " Watchdog Timeout " value.

If this occurs then the 8 outputs will switch to the state defined by the " Output State " values which correspond to the 8 output channels.

If a value is 0, the output will turn OFF, if 1 then it will turn ON and if a 2 then the output will remain as it is.

The Default Setting is 0 as shipped.

On normal Power ON or Reset, all outputs will be OFF.

## MODBUS FUNCTIONS

All data values and Flash memory parameters are accessed via the Modbus RTU protocol as per the "Modbus Application Protocol Specification V1.1b". Available at [www.Modbus-IDA.org](http://www.Modbus-IDA.org)

For reading data values of the 8 input channels, use function code 02 (read input status). You must specify the starting address 0 to 7 (for channel 1 to 8) and the number of Inputs to read ( 1 to 8). Example.....

02      Function code - ( Read Discrete Inputs )  
0000    Starting address – ( begin at channel 1 )  
0008    Number of Inputs – ( all 8 channels )

For reading data values of the 8 output channels, use function code 01 ( read coils ). You must specify the starting address 0 to 7 ( for channel 1 to 8 ) and the number of coils to read ( 1 to 8). Example.....

01      Function code - ( Read coils )  
0000    Starting address – ( begin at channel 1 )  
0008    Number of coils – ( all 8 channels )

For writing data values of all 8 output channels, use function code 06 ( write single register ). You must specify the address 0000 for the output register and an 8 bit value representing the 8 individual channels. Example.....

06      Function code  
0000    Write address 0000 = Output register  
00XX    XX = 8 bit output value (LSB = Channel 1 ) ( 0 = OFF, 1 = ON )

For writing to a single output channel, use function code 05 ( write single coil ). You must specify the starting address 0 to 7 ( for channel 1 to 8 ) and the data value 0000 to turn OFF the output or FFO0 to turn the output ON. Example....

05  
0000    Channel 1 address  
FF00    Turn output ON

In a similar manner, to read the Flash memory parameters, use function code 03 (read holding registers). Example...

03      Function code  
0002    Read address 2 = Sample rate  
0001    One register

To write parameters into the Flash memory, use function code 06 ( write single register ). Example...

06      Function code  
0002    Write address 2 = Sample rate  
003C    Sample rate value = 3C hex = 60 Hz decimal

## ERROR CODES

If any error occurs in these message transactions, the appropriate exception code will be returned to the Master node. The supported codes are as follows:

Code	Meaning
01	Illegal function, not supported by this module
02	Illegal data address, not valid for this module
03	Illegal data value, indicates a fault in the structure of the message.