

FEATURES

- Eight Millivolt Input Channels
- Input Range $\pm 80\text{mV}$, 16bit Resolution
- 3000 Vrms Isolation Input, Power and Network
- 2000 Vrms Channel-to-Channel Isolation
- 250Vrms Signal Overrange Protection
- Highly stable Apix technology A/D Conversion
- 160 db Common Mode Rejection 50/60 HZ
- 90 db Normal Mode Rejection 50/60 HZ
- 50 to 1000 Conversions/Sec with all 8 channels converting synchronously
- Wide Range 9-36 VDC or 7-28 VAC Supply
- -40 to 85 °C Operating Temperature Range
- Synchronized Sampling & Hold of all channels throughout the Network

PRODUCT OVERVIEW

This Modbus RTU version mV Input Module features 8 independent channels and an isolated RS-485 interface.

The channels are fully isolated with 3000 Vrms between Input, Power, RS-485 link and 2000 Vrms Channel-to-Channel.

The module combines Signal Conditioning, robust Isolation, and an individual highly stable 16bit A/D converter per channel. No multiplexers are used. The sampling rate of 50 to 1000 Hz is user settable.

All 8 channels convert synchronously. A global Modbus command will result in synchronized sampling and hold of all Input Channels in the network. These samples are then stored in a second set of registers in each module for eventual readout.

Highly effective multipole digital low pass and notch filters automatically track the set sampling rate.



SPECIFICATIONS

Maximum Ratings

Power Supply Voltage	39VDC or 28VAC
Analog Input	250rms continuous
Storage Temperature	-55 to 125 Deg C
Input Common Mode	3KVrms (1 min)
Channel to Channel Voltage	2KVrms (1 min)
RS-485 Common Mode	2.5KVrms (1 min)

Emissions & Immunity

Complies with the requirements of IEC61000-6-5 and IEC61326-1

In particular :

IEC61000-3-2	Class B emissions
IEC61000-4-2	8KV electrostatic discharge
IEC61000-4-4	4KV burst, 5/50 ns, 5 Khz
IEC61000-4-5	4KV surge 1.2/50 us, line to ground, 2KV line to line
IEC61000-4-6	Conducted RF
IEC61000-4-12	Damped oscillatory wave

Analog Inputs

Voltage Range	$\pm 80\text{ mV}$
Bandwidth	30% of Sample Rate (-3db)
Input Resistance	1 Mohm $\pm 5\%$
Normal Mode Rejection	90 db at 50/60 Hz sample rate

Common Mode

Rejection	160 db at 50/60 Hz sample rate
Leakage Current	2 μA rms at 1000 Vrms and 50/60 Hz, per channel
Capacitance	4 pF max per channel

Power Requirements

Supply Voltage	9 to 36 VDC or 7 to 28 VAC
Max Power	1.8 W, Non Polarized

Performance

Initial Accuracy	$\pm 0.01\%$ of Span, max
Zero Drift	$\pm 10\text{ ppm}/^\circ\text{C}$ of Span, max
Span Drift	$\pm 20\text{ ppm}/^\circ\text{C}$, max
Resolution	16bits ($\pm 80\text{mV} \Rightarrow \pm 32000\text{ decimal}$)
Sample Rate	50 to 1000 samples/sec (All 8 channels simultaneously)

RS-485 Interface

Protocol	Modbus RTU
Baud Rate	2400 to 921.6K standard baud rates, default = 19200
Duplex	Half duplex
Parity	None
Data bits	8
Stop bits	2
Response Delay	0 to 6553.5 msec in 0.1 msec increments
Module Address	1 to 247
Max nodes	1 to 31 without repeater
Max distance	4000 ft, 1230 meters (varies with baud rate)

Environmental & Mechanical

Operating Temperature	-40 to 85 °C
Relative Humidity	< 95 % Non Condensing
Overall Dimensions	113.6 x 117.2 x 22.5 (mm), 4.47 x 4.62 x 0.89 (in)
Enclosure material	PA 66 GF 30
PC Board material	FR4
Protection Class	IP20
Conductor Size	AWG26 min, AWG14 max

Functional Block Diagram

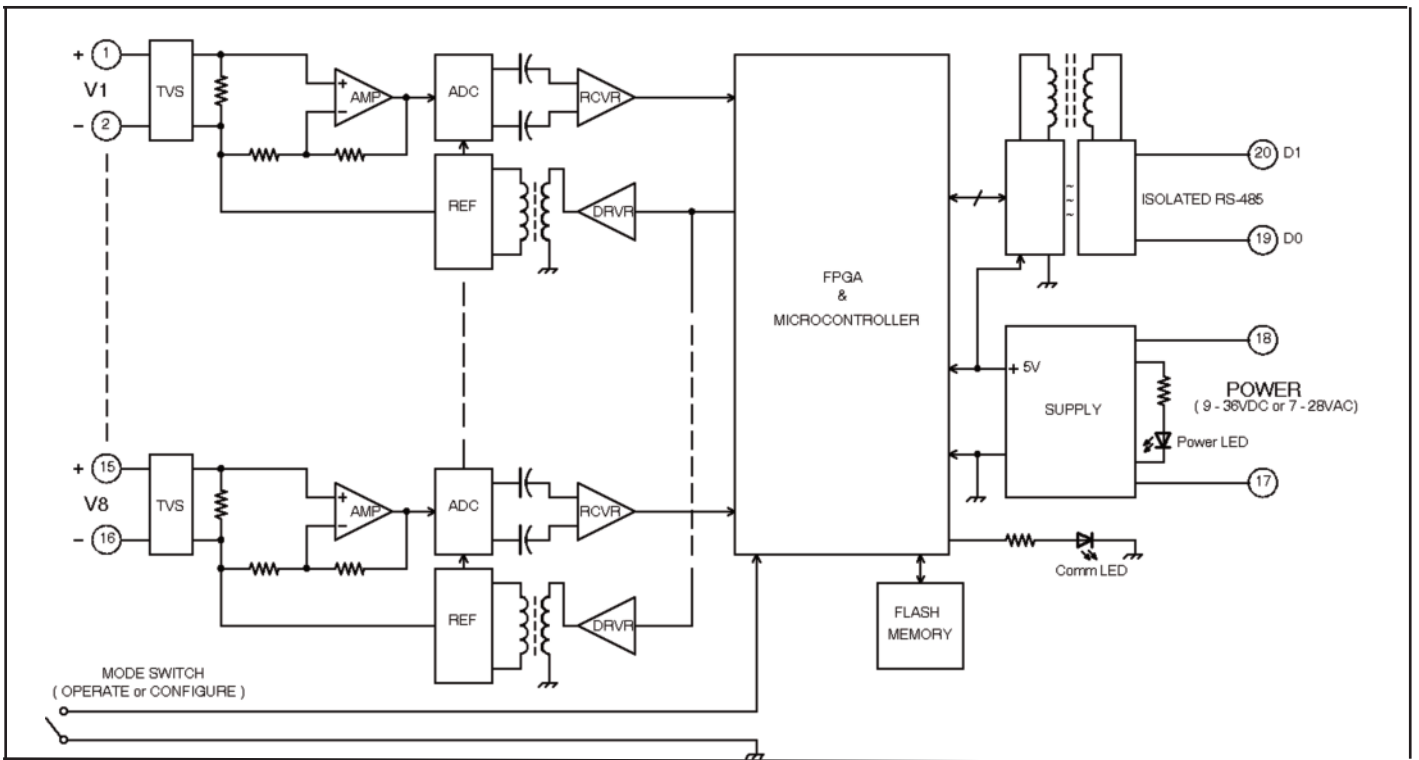

OPERATION

The Functional Block Diagram shows how the external voltage inputs are connected to the eight identical isolated processing channels. Each channel has Transient Voltage Suppressor Network across the input terminals, followed by signal conditioning, AD conversion and isolation. The channel input resistance is 1Mohm. A transformer and associated driver (DRV) supply power for the channel.

Output values from the ADCs are isolated by high voltage capacitors and differential receivers (RCVR) and are passed on to the FPGA—Microcontroller for digital filtering, calibration and transmission to the Modbus network. External power at the PWR terminals is indicated by the “Power” LED.

An isolated RS-485 interface drives the network cable. The “Comm” LED turns ON when the module is transmitting. A watchdog timer will restart the module if any unusual event disrupts normal operation.

INSTALLATION

Enclosure

All ISODIN modules offer IP20 level protection to withstand typical industrial environments. The thermoplastic package is non-flammable per UL94 V-0 with high impact resistance.

They feature surge protection on each input and have low radiated emissions and high immunity tolerance.

Mounting

This module must be mounted vertically on a 35mm "T" type DIN rail as per EN50022.

Module attachment is done by locating the top groove of the adapter over the upper lip of the rail then pushing the unit downwards until it snaps into place.

Removal is accomplished by inserting a screwdriver into the groove of the bottom side latch and using it as a lever to open the latch until the module disconnects from the rail.

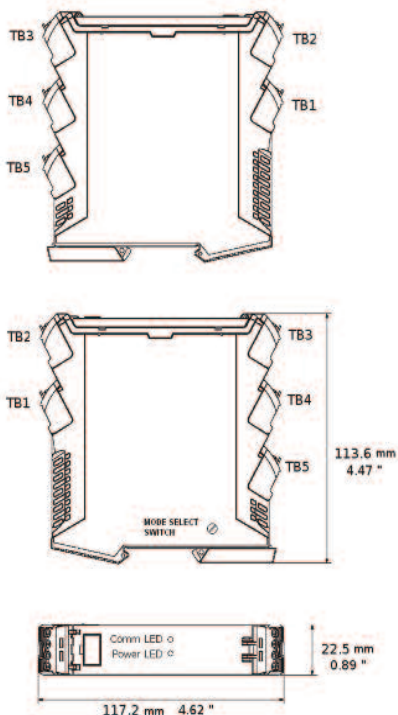

CONNECTIONS

There are 5 plug-in terminal blocks, TB1—TB4 for voltage input wiring and one 5 pin terminal, TB5 for power and RS-485 connections. These terminal blocks and Millivolt input signal polarities are clearly indicated on the module side label. TB1-TB5 have a convenient lever mechanism for easy ejection.

All terminals will accept from AWG26 up to AWD14 wire and are rated 10A/400V at ambient temperature and II/2 pollution severity.

Voltage inputs should preferably use twisted pair cables, with or without shields, to minimize external magnetic field pickup, thus preserving the excellent 16bit resolution and signal to noise ratio.

The power input can be from 9 to 36VDC or 7 to 24VAC and connects to the PWR terminals. An internal diode protects against accidental reverse polarity connection. A Green LED, labeled “Power” on the front panel is fed directly by the power input.

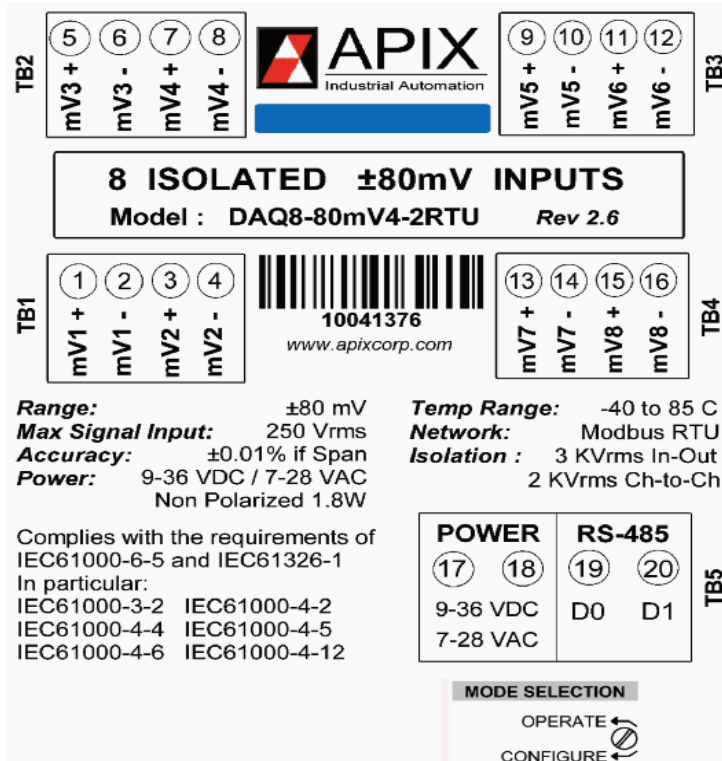

A twisted pair cable should be used for the RS-485 signal and daisy chained from module to module, without branching. Terminals labeled D0 and D1, as per the Modbus specification, carry the differential half duplex RS-485 signal. A cable shield is not normally required but if available should be connected to chassis (DIN rail) ground. Since this RS-485 link is isolated, there is no current flow along the shield drain wire.

RS-485 line polarization is required for proper operation of this module. This is usually provided by the Modbus Master node via pullup and pulldown resistors. The Master node should also provide a 120 or 150 ohm line termination resistor across the D0 & D1 pins. If the cable is very long and reflections are a problem, then a second termination resistor, at the far end of the cable, may be required.

CONFIGURATION

An external MODE Rotary Switch must be set to the “CONFIGURE” position (fully clockwise) in order to permit changes to all internal parameters.

The procedure is as follows:

- 1) Power must be OFF
- 2) Turn MODE switch fully clockwise
- 3) Power ON
- 4) Change any parameters as necessary
- 5) Power OFF
- 6) Turn MODE switch fully counterclockwise (OPERATE position , default)
- 7) Power ON to operate normally

NOTE that the MODE switch state will be recognized only when power is applied.

In the CONFIGURE position , default communication parameters are set as follows:

Module address = 1
Baud rate = 19200
Sample rate = 50

All user accessible parameters are stored in Flash memory and can be read and written to as “Holding Registers”, via the Modbus RTU protocol (function codes 3 and 6), in the following locations:

Register Address	Name	Value Range
0	Module ID	3 (DAQ8-80mV4-2RTU)
1	Module Address	1 to 247
2	Sample Rate	50 to 1000
3	Baud Rate	24 to 9216 (Actual rate divided by 100)
4	Parity	0=none, 1=odd, 2=even
5	Response Delay	0 to 65535 (equals 0 to 6553.5 msec)
6	Reserved	
7	Reserved	
8	Offset channel 1	-32768 to 32767
9	Offset channel 2	-32768 to 32767
10	Offset channel 3	-32768 to 32767
11	Offset channel 4	-32768 to 32767
12	Offset channel 5	-32768 to 32767
13	Offset channel 6	-32768 to 32767
14	Offset channel 7	-32768 to 32767
15	Offset channel 8	-32768 to 32767
16	Gain channel 1	0 to 65535
17	Gain channel 2	0 to 65535
18	Gain channel 3	0 to 65535
19	Gain channel 4	0 to 65535
20	Gain channel 5	0 to 65535
21	Gain channel 6	0 to 65535
22	Gain channel 7	0 to 65535
23	Gain channel 8	0 to 65535

Due to the nature of Flash memory, it can be read very quickly but when writing to a single location it actually writes a complete block of 65536 locations. This can take several seconds to complete.

Please note that the offset and gain values are set very precisely at the factory and should not need to be modified.

MODBUS FUNCTIONS

All data values and Flash memory parameters are accessed via the Modbus RTU protocol as per the "Modbus Application Protocol Specification V1.1b". Available at www.Modbus-IDA.org

For reading data values of the 8 input channels, use function code 04 (read input registers). You must specify the starting address 0 to 7 (for channel 1 to 8) and the number of registers to read (1 to 8). Example.....

04 Function code - (Read input registers)
0000 Starting address – (begin at channel 1)
0008 Number of registers – (all 8 channels)

In a similar manner, to read the Flash memory parameters, use function code 03 (read holding registers). Example...

03 Function code
0002 Read address 2 = Sample rate
0001 One register

To write parameters into the Flash memory, use function code 06 (write single register). Example...

06 Function code
0002 Write address 2 = Sample rate
003C Sample rate value = 3C hex = 60 Hz decimal

SYNC COMMAND

A Modbus global broadcast command has been implemented to take a synchronized sample of all Input Channels in the network. When this command is received by the module, it immediately starts a new sample (discarding any ongoing AD conversions) on all 8 channels simultaneously. This broadcast command is 2 bytes ...

00 Broadcast address
01 Take sample

These samples are then stored in a second set of 8 registers for eventual readout. This second set of registers begins at address 8 and ends at address 15 and can be accessed as "Input registers" in the normal manner, for example...

04 Function code - (Read input registers)
0008 Starting address - (begin at channel 1 of second register set)
0008 Number of registers - (all 8 channels)

ERROR CODES

If any error occurs in these message transactions, the appropriate exception code will be returned to the Master node. The supported codes are as follows:

Code	Meaning
01	Illegal function, not supported by this module
02	Illegal data address, not valid for this module
03	Illegal data value, indicates a fault in the structure of the message.